

CONTROL UNIT

# HLC Series



2 YEARS WARRANTY



ISO 14001



ISO 9001



[www.hitrol.com](http://www.hitrol.com)



Always The Best Solution  
**HITROL CO., LTD.**

## Overview

**HLC Series** is a control unit to be combined with a level switch (HE, HQ, HR Series) for storage tank, functioning of control and alarm. Through the HLC Series, the signal from the level switch can be used for alarm of high and/or low level of the liquid and control of the automatic filling or discharging of the liquid in the tank, and it can be installed on the control panel.

## Characteristics

- Easy to install for controlling of liquid levels in various tanks
- Compact size (HLC-200A)
- Easy to install DIN Rail type
- Socket structure type for freely detachment (HLC-200A)
- Operating can be checked through the LED lamp.
- Sensitivity can be adjusted at the site if the sensor is too much sensitive to the conductivity or foam of the liquid. (HLC-200A)
- Optional power source of DC 24V (HLC-300)

## Operating Principle

- When the level switch connected to HLC Series detects a liquid in the tank, a leakage current flow and it is sensed by leakage current sensing circuit, and transistor is activated. Accordingly, relay contact is changed and it can be used for alarm and/or control signal.

# CONTROL UNIT HLC 300 Series

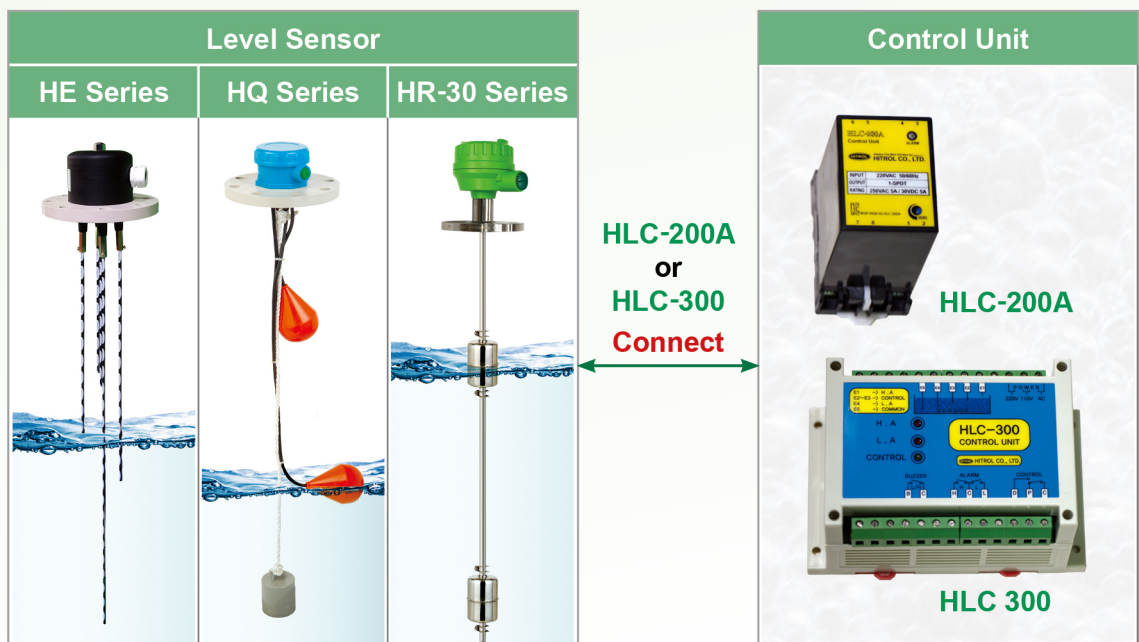



## Specification

### ► General Specification (HLC-200A)

Model	HLC-200A
Installation	Panel Inside (DIN Rail or Bolting)
Ambient Temperature	-20 °C ~ +70 °C
Power Source	AC 110 or 220V @ 50/60Hz
Standby Power Consumption	AC110V @ 0.5W / AC220V @ 0.8W
Active Power Consumption	AC110V @ 1.4W / AC220V @ 2W
Relay Contact	1-SPDT @ AC250V/5A
Contact Load Capacity	AC 250V, 5A Max.
Weight	Body : 200g / Socket : 70g / Total : 270g
Housing Material	Body (Flame Retardant ABS) / Socket (PBT Glass)

### ► General Specification (HLC-300)

Model	HLC-300
Installation	Panel Inside (DIN Rail or Bolting)
Ambient Temperature	-20 °C ~ +60 °C
Power Source	AC 110 / 220V @ 50/60Hz Option DC 24V (Opt.)
Standby Power consumption	AC 110V @ 0.8W / AC 220V @ 0.9W
Active Power Consumption	AC 110V @ 2.3W / AC 220V @ 2.5W
Relay Contact	2-SPST / 1-SPDT @ AC250V / 5A
Contact Load Capacity	AC 250V, 5A , DC 30V 5A
Weight	430g
Housing Material	Body (PC)

► **Order Code** can be printed at our website ([www.hitrol.com](http://www.hitrol.com))



# Dimension

## HLC-200A

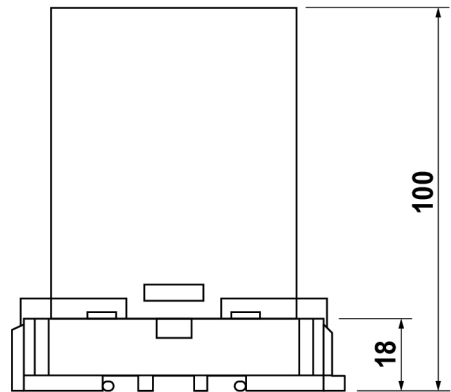
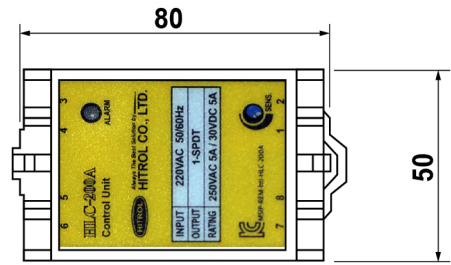
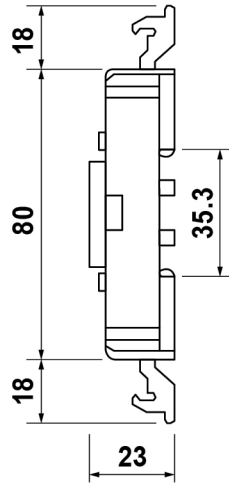
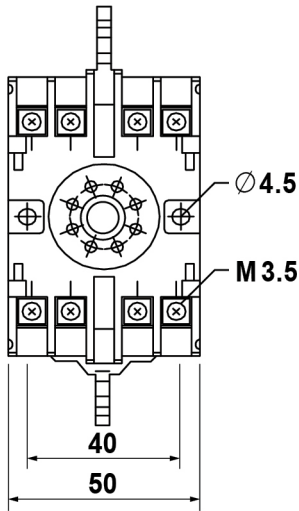

< HLC-200A Socket >

## HLC-300

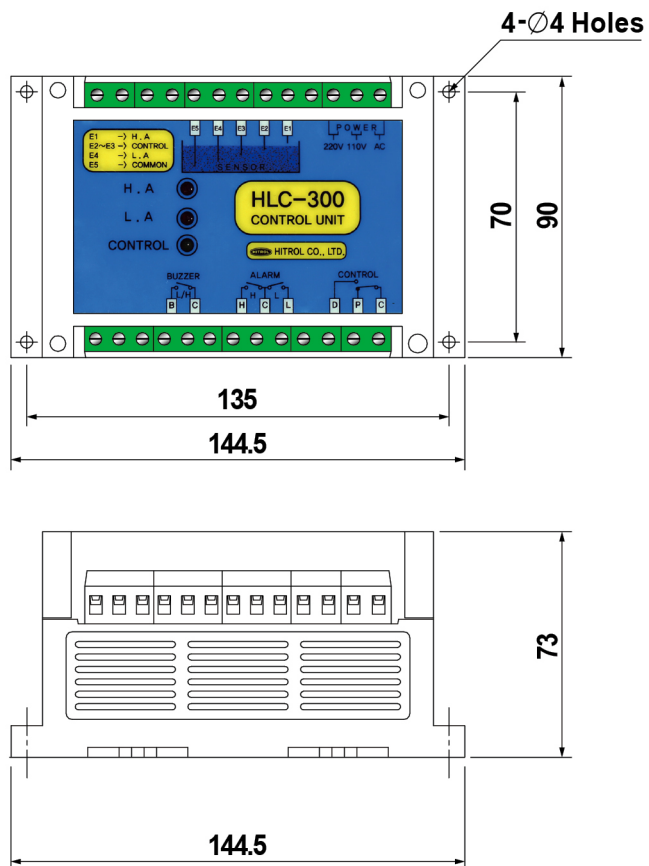

■ Actual product may have a tolerance slightly.





# Connection Diagram

### HLC-200A Connection Diagram

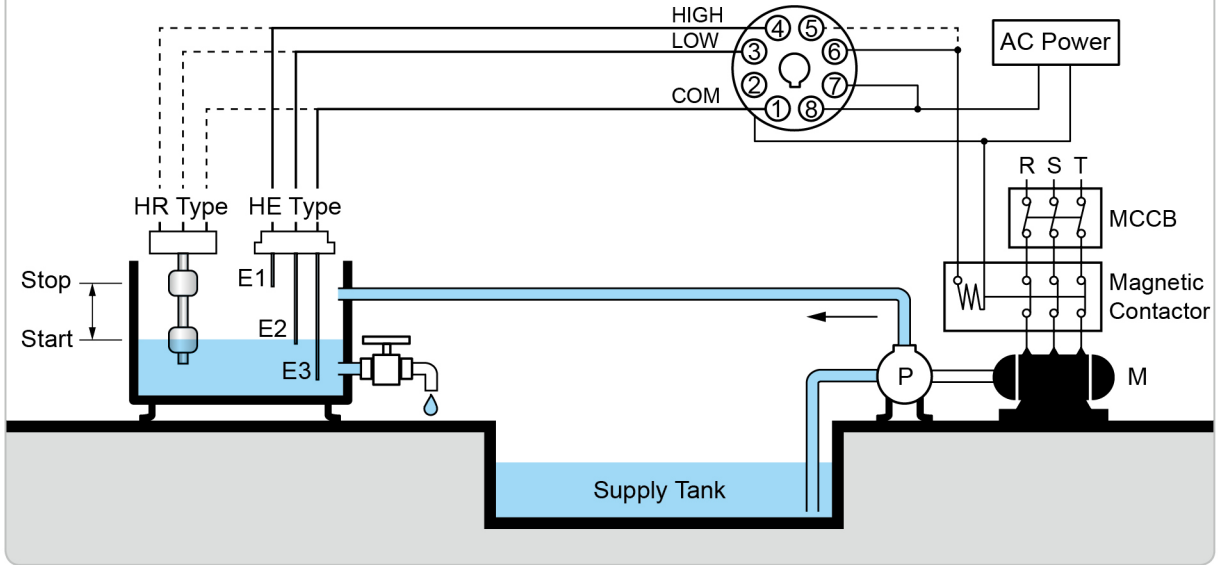

### HLC-300 Connection Diagram

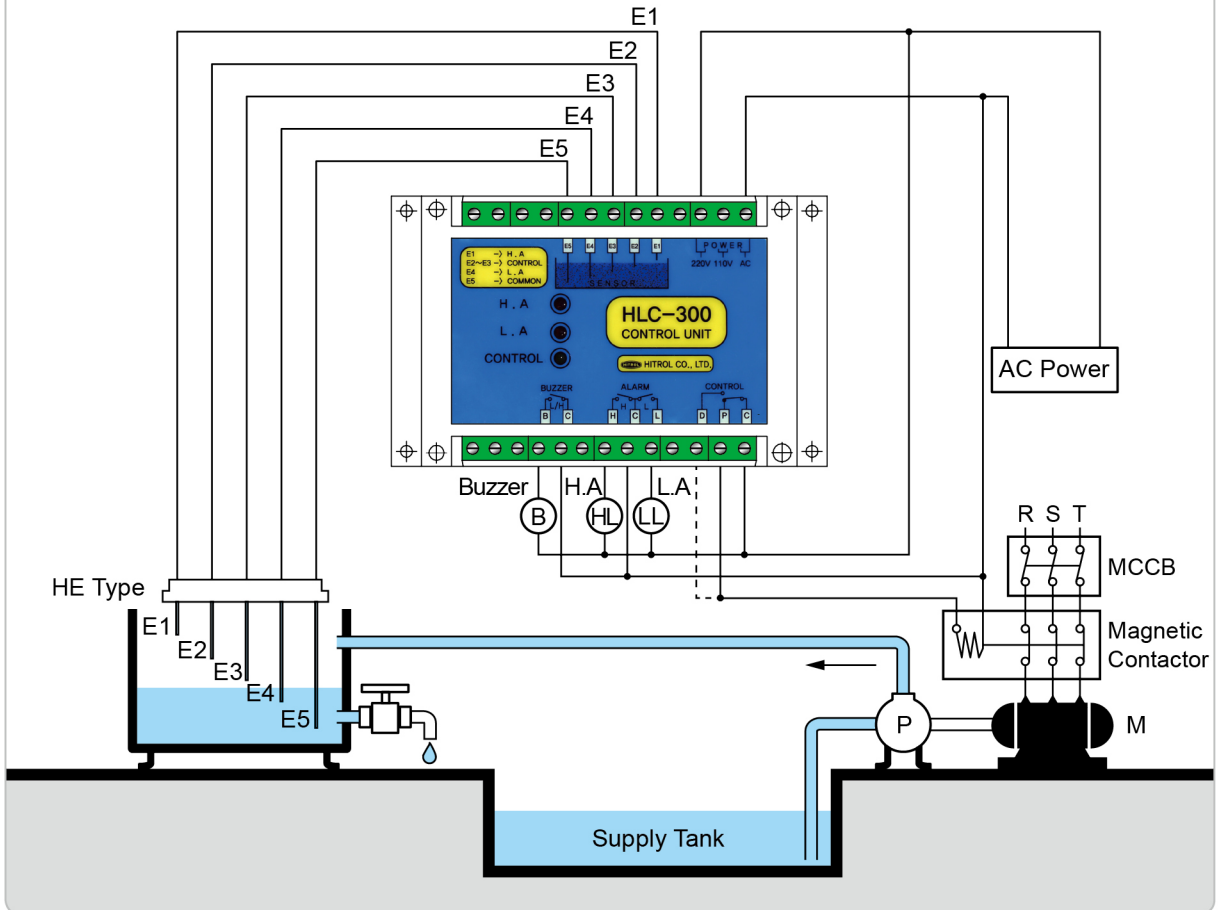

---

# HLC Series

---

*Easy to Install DIN Rail Type*



*Compact Size (HLC-200A)*

*Operating can be checked with LED lamp*